

TriaAir[®]

Ventilationsanlæg

Tekniske data

J Prime 25_90, ROTOR



Varenr.: QB09000250
ROTOR

Standardfarve: RAL 9002 glans 30 (hvid)



TECHNICAL DATA			
Date	21.08.2020	Rev. Date	14.09.2020
Project ID	4157	Tracking Number	4126
Project Name	Item no. QB09000250		
AHU Name	J Prime_25_90		
AHU Model	JUPITER 12 X 20		



Ecodesign Requirements Table

		Value		2018
	Product	JUPITER 25		
	Erp	2018		
A	Manufacturer	BSK Havalandırma Ekipmanları A.Ş.		
B	Model Identifier	JUPITER 12 X 20		
C	ErP Code	NRVU - BVU		
D	Type Of Drive	Variable Speed Drive (VSD)In	Variable Speed Drive (VSD)Out	Required
E	Type Of HRS	Rotary		
	HRS Damper	Exists		Exists Required
F	Thermal Efficiency of HRS	74,45 %		74,45 % >= 73 %
G	Nominal Flow Rate	2,35 m³/s	2,35 m³/s	
H	Effective Electrical Power Input	2,55 kW	2,57 kW	5,12 kW
I	SFPInt	430 W/(m³/s)	391 W/(m³/s)	821W/(m³/s) <= 844
J	Face Velocity	1,58 m/s	1,54 m/s	
K	Nominal External Drop Δps, Ext	250 Pa		250 Pa
L	Internal Pressure Drop Δps, Int Supply Air	253 Pa		253 Pa
	Internal Pressure Drop Δps, Int. Exhaust Air	258 Pa		258 Pa
M	Additional Pressure Drop Δps, Add	106 Pa	106 Pa	
N	Static Fan Efficiency EC327/2011	50,25 %	50,47 %	
O	Declared Maximum Ext./Int. Leakage Rate	1,00 %		1,00 %
	Leakage Classifications by Eurovent	L1		L1
P	Energy Performance Of Filters	E	E	
Q	Description Of Visual Filter Warning	Manometer Pressure Gauge	Manometer Pressure Gauge	Required
R	Casing Sound Power Level (Lwa)	65,5 dBA		65,5 dBA
S	Internet Address Of Instructions	www.Termicplus.dk		
	Total Dimension mm	W 1.660 x H 2.235 x L 2.150		
	Supply Airflow	8.450 m³/h		8.450 m³/h
	Return Airflow	8.450 m³/h		8.450 m³/h
	Design Outdoor Temp. Summer	(+25,8°C) (Hum. 60%)		(+25,8°C)
	Design Outdoor Temp. Winter	(-12 °C) (Hum. 90%)		(-12 °C)
	FRESH AIR CONNECTION Air Velocity	2,40 m/s		2,40 m/s
	SUPPLY CONNECTION Air Velocity	2,40 m/s		2,40 m/s
	RETURN CONNECTION Air Velocity	2,40 m/s		2,40 m/s
	EXHAUST CONNECTION Air Velocity	2,40 m/s		2,40 m/s
	Total Heating Capacity			
	Fluid Kind for Heating			
	Fluid Temp. In / Out (Heating)			
	Total Cooling Capacity			
	Fluid Kind for Cooling			
	Fluid Temp. In / Out (Cooling)			
	Filter Type supply Air	F7 Panel		F7 Panel
	Filter Type Return Air	M6 Panel		M6 Panel
	Total Weight	1.240 kg		1.240 kg

Accessories	Connection possible (Motherboard)	Included in the unit	Overall Total values
Co2 sensor	Yes	No	
Motion Sensor	Yes	No	
Heating Module	Yes	No	
Cooling Module	Yes	No	
Hood for supply air	Yes	No	
Hood for Exhaust air	Yes	No	
VAV	Yes	No	
Heating coil valve	Yes	No	
Cooling coil valve	Yes	No	
Electric Pre-heater	Yes	No	
Electric Heater	Yes	No	
Fire/smoke Automatic	Yes	No	
Steam Humidifier (M7)	Yes	No	
Prepared to fire	Yes	No	
Prepared to Smoke	Yes	No	
Motherboard/Display	Yes	Yes	
Kitchen Unit	Yes	No	
Unit Used as a smoke fan	Yes	No	

Air Flow

J Prime 25_90

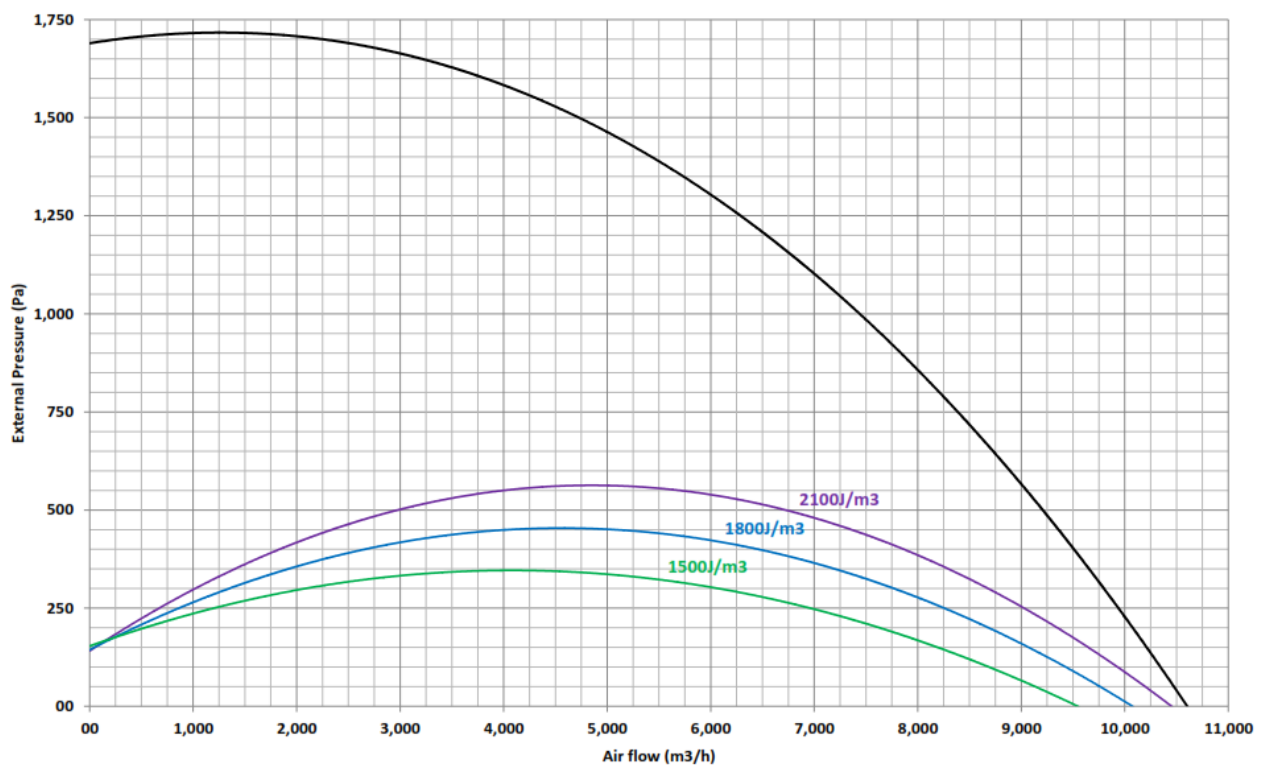

Efficiency Jprime 25_90

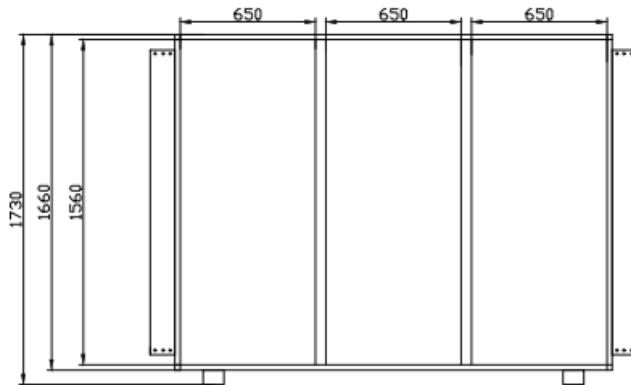
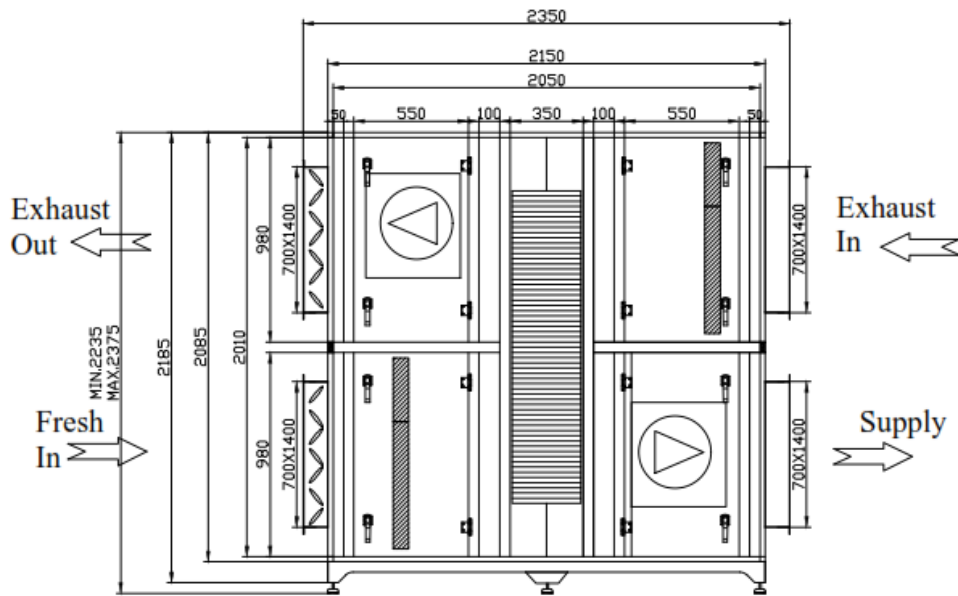
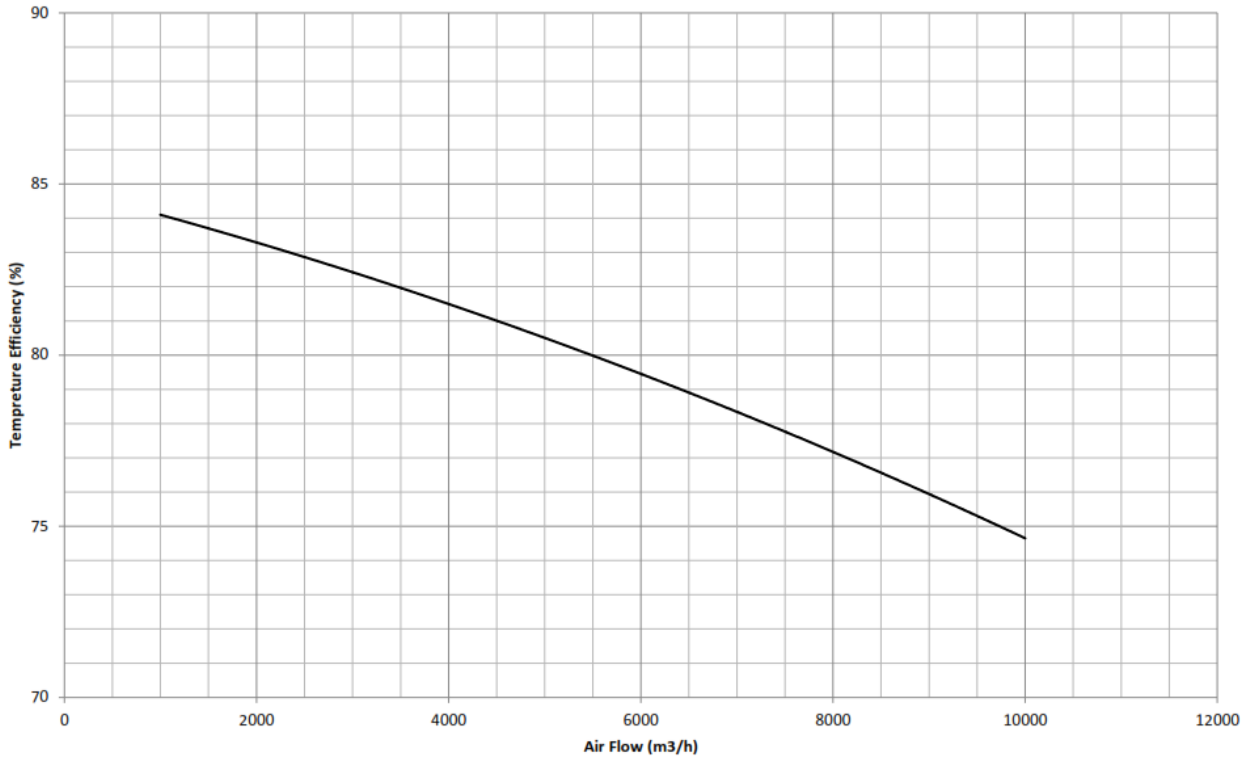

NOTE: ALL DIMENSIONS ARE MM

Flange Dimensions

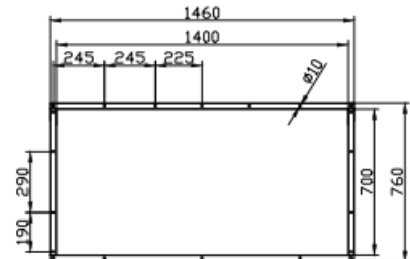



ATTESTATION OF CONFORMITY UYGUNLUK ONAYI

Sertifika Numarası / Certificate Number : M.2020.ST.1195.01

Üretici <i>Manufacturer</i>	: BSK Havalandırma Ekipmanları Anonim Şirketi
Üretici Adresi <i>Manufacturer adress</i>	: Mimar Sinan Mah. Basra Cad. No:59 Sultanbeyli İSTANBUL / TÜRKİYE
Ürün Tanımı <i>Product description</i>	: Klima Santrali Standart&Hygienic Air Handling Units
Tip / Model <i>Type / Model</i>	: BSK JUPITER Serisi: 500m ³ /h - 100.000m ³ /h
İlgili Yönetmelikler <i>Related Directives</i>	: 2006/42/AT Makina Emniyeti Yönetmeliği/EK VIII 2006/42/EC Machinery Directive/Annex VIII
İlgili Standartlar <i>Related Standards</i>	: EN ISO 12100,EN ISO 14120,EN ISO 13849-1, EN 60204-1
Denetim Raporu <i>Audit Report</i>	: ST.1195.01

UDEM Adriatic d.o.o. adı ve adresi yukarıda belirtilen firmanın sunduğu teknik dokümanları inceleyerek, belirlenen ürünün Makina Emniyeti Yönetmeliği 2006/42/AT Ek VIII kurallarına uygunluğunu onaylar. Yukarıda belirtilen tiplerdeki ürün üzerine CE işaretini, üreticinin kendi sorumluluğunda hazırlayacağı AT Uygunluk Beyanı ile iliştirebilir. İncelemesi yapılan ürüne ait olan bu belge tasarımın değişmesi halinde geçerliliğini yitirecektir. Bu belgenin geçerliliğini www.udemadriatic.com internet sayfasından kontrol edebilirsiniz. Bu belge sadece yukarıda adı geçen ürün tip/modelleri için geçerlidir. Yukarıda adı geçen firma ve UDEM bu belgelerin bir kopyasını tescil tarihinden itibaren 15 yıl süreyle muhafaza etmelidir. Bu belgenin mülkiyet hakkı UDEM Adriatic d.o.o 'ya aittir ve istenildiğinde iade edilmelidir.

UDEM Adriatic d.o.o. confirms by examining technical documents presented on the part of company which stated title and address below that product is conformable to 2006/42/EC Annex VIII



Machinery Directive regulations, could attach marking on the product with EC Declaration of Conformity prepared by manufacturer in the charge of company. In case of changing this certificate design regarding to product examined, certificate will be expired. Please check validity of this certificate by website www.udemadriatic.com This certificate is valid just for the product type/models stated below. UDEM and Company above mentioned must retain a copy of these certificates for 15 years since the day of registration. This certificate property belongs to UDEM Adriatic d.o.o and if required it must be returned.

Yayın Tarihi / Issue Date : 29.09.2020

Geçerlilik Tarihi / Validity date : 28.09.2021



Udem Adriatic d.o.o

Adres: Radnička cesta 54/R3, Zagreb Croatia

Tel: +385 (1) 4819 601 Faks: +385 (1) 4819 434

E-posta: info@udemadriatic.com Web: www.udemadriatic.com

EC DECLARATION OF CONFORMITY / AT UYGUNLUK BEYANI



We herewith declare / İş bu beyanname ile



BSK HAVALANDIRMA EKİPMANLARI ANONİM ŞİRKETİ

Address: Mimar Sinan Mah. Basra Cad. No:59 Sultanbeyli İSTANBUL / TURKEY

Product Name: Standart&Hygienic Air Handling Units

Model: BSK JUPITER Serisi:500m3/h - 100.000m3/h

Year of Manufacture/ Serial Number: 2020/001

Regulations Applied

We declare that we meet the following directive conditions for the Air Handling Unit that we have assembled and manufactured.

- 2006/42/EC Machinery Directive/Annex VIII

Application Standard

- EN ISO 12100
- EN ISO 14120
- EN ISO 13849-1
- EN 60204-1

Date and Place of Declaration : 28.09.2020/İSTANBUL

Name and Surname :

Deniz Palat

Signature, Stamp



Address/Adres: Mimar Sinan, Basra Cad. No:59 Sultanbeyli / İstanbul

Phone / Telefon: : + 90 216 669 09 70

Mail: info@bskhavalandirma.com

Web : www.bskhavalandirma.com

DECLARATION OF CONFORMITY

	TECHNICAL DATA			
	Date	21.08.2020	Rev. Date	14.09.2020
	Project ID	4157	Tracking Number	4126kopya
	Project Name	25secim		
AHUSEL V.	2.2.3.17 15.08.2020	AHU Name		J Prime_25_90 - (1 QTY)
BSK	1/6	AHU Model		JUPITER 12 X 20

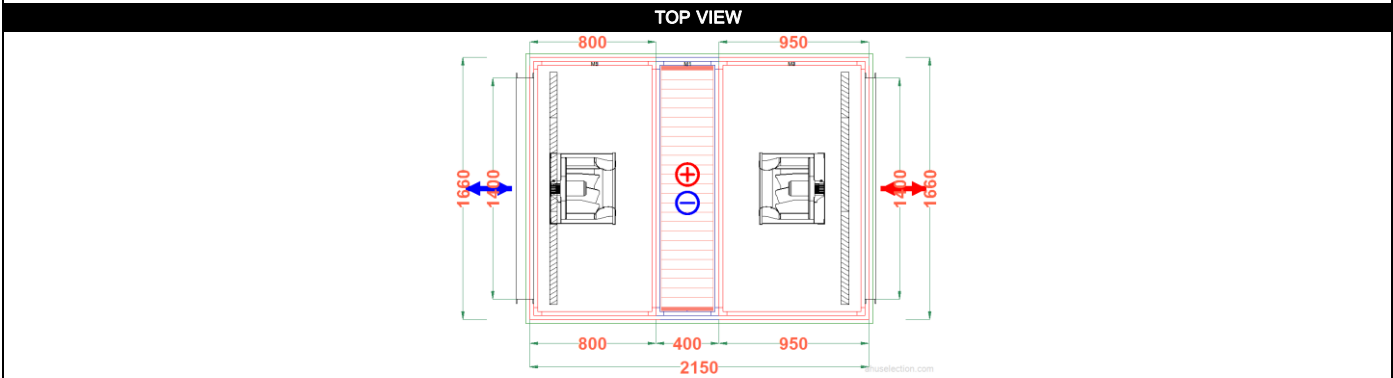
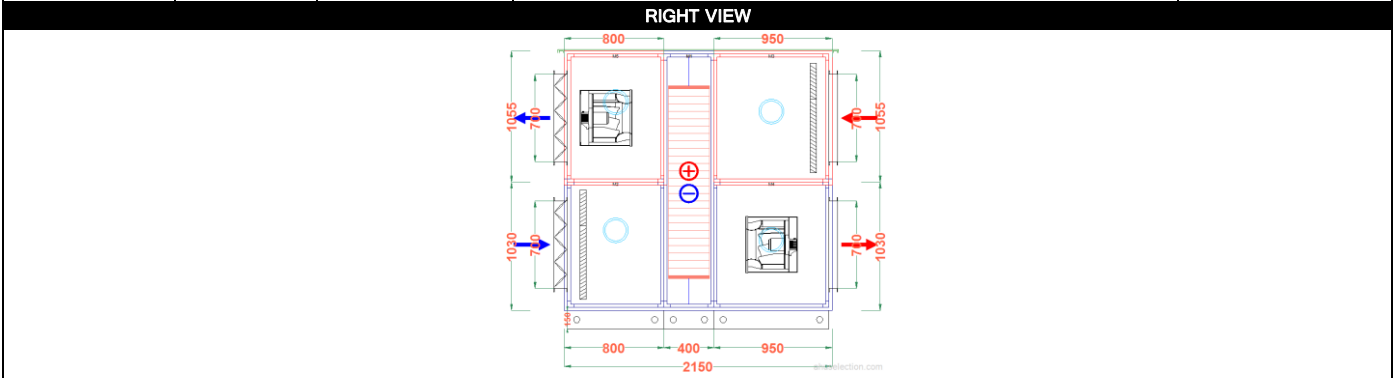

GENERAL SPECIFICATIONS

Supply Air Flow	Return Air Flow	Frame	Total Dimensions mm	
8.450 m³/h	8.450 m³/h	25 steel profile	W 1.660 x H 2.235 x L 2.150	
Supply Air Velocity	Return Air Velocity	Insulation Material	Total Weight	
1,58 m/s	1,54 m/s	50 mm Rockwool 70 kg/m³	1.240 kg	
	Air Density	Outside Sheet Material	Base Height	Roof (Outside)
	1,3504 kg/m³	0,9 mm Painted Galvanize	150 mm	Sheet
Design Outdoor Temp.(W-S)		Inside Sheet Material	Total Absorbed Power	
(-12°C/90%)-(25,80°C/60%) (Odense)		0,9 mm Galvanize	5,12 kW	
		Total Sensible Capacity	Motor Power(Vent/Asp)	
			3,65 kW / 3,65 kW	
Specific Fan Power(SFP Total)	ErP Compliance	ErP Code	Real Unit CAL Class -400 Pa	Real Unit CAL Class +400 Pa
0,82 kW/(m³/s)	2018	NRVU - BVU	L1	L2

SOUND POWER LEVEL (dB)

Frequency Hz	125	250	500	1000	2000	4000	8000	LwA-tot	
Airborne Sound Power Level	70,2	69,3	65,0	56,2	57,5	45,8	40,2	65,5	dBA
Air Outlet Induct Sound Power Level	82,3	90,2	89,1	86,5	85,6	78,1	80,5	91,6	dBA
Air Inlet Induct Sound Power Level	85,3	83,5	78,6	65,2	58,7	48,4	47,9	78,6	dBA
Return Air Outlet Induct Sound Power Level	82,3	90,2	89,1	86,5	85,6	78,1	80,5	91,6	dBA
Return Air Inlet Induct Sound Power Level	85,3	83,5	78,6	65,2	58,7	48,4	47,9	78,6	dBA

ACCESSORIES



Lightening, Observation Glass, Manometer Pressure Gauge

Model	CS Class	CAL Class -400 Pa	CAL Class +700 Pa	FBL Class	TT Class	TBF Class	Casing acoustical insulation at 125 Hz [dB]	Casing acoustical insulation at 250 Hz [dB]	Casing acoustical insulation at 500 Hz [dB]	Casing acoustical insulation at 1000 Hz [dB]	Casing acoustical insulation at 2000 Hz [dB]	Casing acoustical insulation at 4000 Hz [dB]	Casing acoustical insulation at 8000 Hz [dB]
JUPITER*	D2	L1	L1	F9	T2	TB2	18,4	27,2	30,1	35,4	33,3	36,5	43,9

*These results obtained according to Eurovent modelbox test.

www.bskhavalandirma.com.tr	Office Tel:	+90 216 669 09 70	Factory Tel:	+90 216 669 09 70
info@bskhavalandirma.com.tr	Office Fax:	+90 216 669 09 72	Factory Fax:	+90 216 669 09 72



		TECHNICAL DATA				
		Date	21.08.2020	Rev. Date	14.09.2020	
		Project ID	4157	Tracking Number	4126kopya	
		Project Name	25secim			
AHUSEL V.	2.2.3.17 15.08.2020	AHU Name	J Prime_25_90 - (1 QTY)			
BSK	2/6	AHU Model	JUPITER 12 X 20			
FRESH AIR CONNECTION						
Connection Type		Control Type		Pressure Drop		
Gear Damper		Automatic (LM230ASR)		0 Pa		
Airflow		Dimensions		Air Velocity		
8.450 m³/h		W 1.400 mm x H 700 mm		2,40 m/s		
SUPPLY CONNECTION						
Connection Type		Control Type		Pressure Drop		
Flange				0 Pa		
Airflow		Dimensions		Air Velocity		
8.450 m³/h		W 1.400 mm x H 700 mm		2,40 m/s		
RETURN CONNECTION						
Connection Type		Control Type		Pressure Drop		
Flange				0 Pa		
Airflow		Dimensions		Air Velocity		
8.450 m³/h		W 1.400 mm x H 700 mm		2,40 m/s		
EXHAUST CONNECTION						
Connection Type		Control Type		Pressure Drop		
Gear Damper		Automatic (LM230ASR)		0 Pa		
Airflow		Dimensions		Air Velocity		
8.450 m³/h		W 1.400 mm x H 700 mm		2,40 m/s		
FILTER (M2)						
Airflow	Condensation Pan			Spare Filter	Section Weight	
8.450 m³/h					241 kg	
Filter Type	Initial / Final / Design P.Drop	Air Velocity	Size/Quantity/EC*	Size/Quantity/EC*	Size/Quantity/EC*	Size/Quantity/EC*
F7 Panel	83 Pa / 183 Pa / 133 Pa	1,94 m/s	592x592x48/2/E	592x287x48/3/E		
* Filter Energy Performance; preferably energy classification						
* Frame sealing applied.						
ACCESSORIES (M2)						
Lightening, Observation Glass, Manometer Pressure Gauge						

	TECHNICAL DATA			
	Date	21.08.2020	Rev. Date	14.09.2020
	Project ID	4157	Tracking Number	4126kopya
	Project Name	25secim		
AHUSEL V.	2.2.3.17 15.08.2020	AHU Name	J Prime_25_90 - (1 QTY)	
BSK	3/6	AHU Model	JUPITER 12 X 20	



ROTARY HEAT EXCHANGER (M1)

Model	Rpm	Quantity	Section Weight
RRU_ECO-P-E20-1550/1550-1500	15	1	321 kg

	Fresh Air	Exhaust	Capacity	Winter	Summer		
Airflow	8.450 m³/h	8.450 m³/h		105,16 kW	-3,66 kW		
Air Vel.	2,36 m/s	2,70 m/s	P.D	Fresh	Exhau	Fresh	Exhaus
	Winter	Summer		104 Pa	123 Pa	133 Pa	123 Pa
	Effic.	Balan.(*)	1,2kg/m³	129 Pa	121 Pa	129 Pa	121 Pa
	74,45	74,45		71,07	71,07		

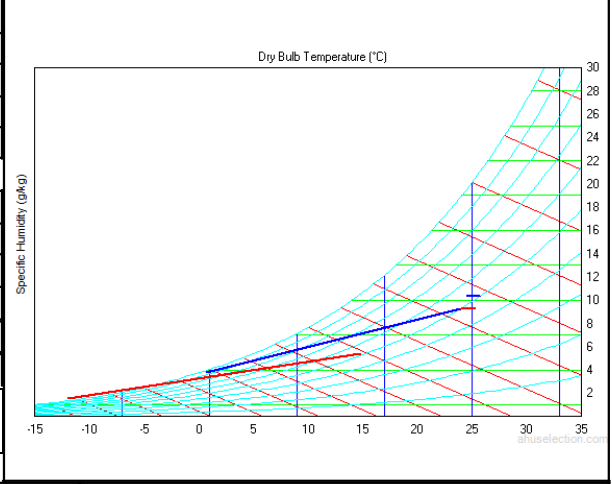

Air Inlet / Outlet	Winter				Summer			
	Fresh Air		Exhaust		Fresh Air		Exhaust	
	Inlet	Outlet	Inlet	Outlet	Inlet	Outlet	Inlet	Outlet
	DT	-12,00 °	14,80 °C	24,00 °C	0,70 °C	25,80 °C	24,52 °C	24,00 °C
WT	-12,00 °	9,75 °C	17,07 °C	0,41 °C	18,55 °C	18,12 °C	17,07 °C	17,51 °C
RH	100,00	52,06 %	50,00 %	95,00 %	50,00 %	53,96 %	50,00 %	46,32 %

Condensation Pan	OACF (*)	EATR (%) (*)
	0,00	0,00

<input type="checkbox"/> Frequency Inverter	Size mm (1.550 x 1.550 x 330) - 1.500	Bypass Damper
---	--	---------------

* Efficiency at balanced flow

* OACF: Outdoor Air Correction Factor, EATR: Exhaust Air Transfer Ratio

ACCESSORIES (M1)



www.bskhavalandirma.com.tr	Office Tel: +90 216 669 09 70	Factory Tel: +90 216 669 09 70
info@bskhavalandirma.com.tr	Office Fax: +90 216 669 09 72	Factory Fax: +90 216 669 09 72



	TECHNICAL DATA			
	Date	21.08.2020	Rev. Date	14.09.2020
	Project ID	4157	Tracking Number	4126kopya
	Project Name	25secim		
AHUSEL V.	2.2.3.17 15.08.2020	AHU Name	J Prime_25_90 - (1 QTY)	
BSK	4/6	AHU Model	JUPITER 12 X 20	



SUPPLY FAN (M4)

Airflow	8.450 m ³ /h	Fan Model	EBM Papst-R3G400PA2703			Quantity	1	Section Weight	246 kg			
Internal Static Pressure	253 Pa	Motor P./Pha./Volt./Freq.	3,65 kW/3P/400V/50-60Hz			Isolator		Isolator Count				
External Static Pressure	250 Pa				Backup Fan		Backup Motor					
Total Static Pressure	503 Pa											
Total Pressure	609 Pa								System Effect	16 Pa		
Total / Static Efficiency	60,82 / 50,25 %											
Shaft Power / Absorbed Power	2,35 / 2,55 kW								Absorbed Pow.With VFD	2,55 kW		
Fan Speed	2485 rpm (Max.2800 rpm)	Air Density	1,2000 kg/m ³									
Specific Fan Power (SFP _e int)	0,43 kW/(m ³ /s)	Sound Power Level (dB)										
Electrical Current	3,69 A (Max.5,73 A)	Hz	63	125	250	500	1000	2000	4000	8000	LwA-tot	
		SPLm - Outlet Side	74,9	76,3	82,0	84,5	86,5	88,2	81,4	84,7	92,7	dBA
		SPLa - Inlet Side	70,8	75,1	82,1	83,7	77,8	77,1	74,6	84,7	87,2	dBA

* The fan system effect is taken into account in the fan performance

* The fan calculated for wet conditions

* Sfp is calculated based on clean filter & dry coil conditions

ACCESSORIES (M4)

Lightening, Observation Glass	
-------------------------------	---

FILTER (M3)



Airflow	8.450 m ³ /h	Condensation Pan		Spare Filter		Section Weight	218 kg
Filter Type	M6 Panel	Initial / Final / Design P.Drop	68 Pa / 168 Pa / 118 Pa	Air Velocity	1,94 m/s	Size/Quantity/EC*	592x592x48/2/E
						Size/Quantity/EC*	592x287x48/3/E
						Size/Quantity/EC*	

* Filter Energy Performance; preferably energy classification

* Frame sealing applied.

ACCESSORIES (M3)

Lightening, Observation Glass, Manometer Pressure Gauge	
---	---

	TECHNICAL DATA				
	Date	21.08.2020	Rev. Date		14.09.2020
	Project ID	4157	Tracking Number		4126kopya
	Project Name	25secim			
AHUSEL V.	2.2.3.17 15.08.2020	AHU Name		J Prime_25_90 - (1 QTY)	
BSK	5/6	AHU Model		JUPITER 12 X 20	

EXHAUST FAN (M5)

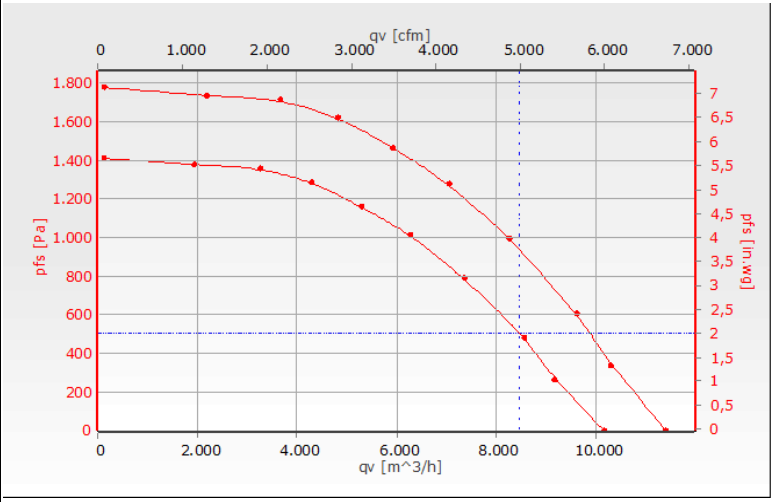
Airflow	8.450 m ³ /h	Fan Model	EBM Papst-R3G400PA2703		Quantity	1	Section Weight	215 kg				
Internal Static Pressure	258 Pa	Motor P./Pha./Volt./Freq.	3,65 kW/3P/400V/50-60Hz		Isolator		Isolator Count					
External Static Pressure	250 Pa				Backup Fan		Backup Motor					
Total Static Pressure	508 Pa											
Total Pressure	614 Pa											
System Effect	17 Pa											
Total / Static Efficiency	60,97 / 50,47 %											
Shaft Power / Absorbed Power	2,36 / 2,57 kW											
Fan Speed	2489 rpm (Max.2800 rpm)	Absorbed Pow.With VFD	2,57 kW									
		Air Density	1,2000 kg/m ³									
Specific Fan Power (SFPe int)	0,39 kW/(m ³ /s)	Sound Power Level (dB)										
		Hz	63	125	250	500	1000	2000	4000	8000	LwA-tot	
Electrical Current	3,71 A (Max.5,73 A)	SPLm - Outlet Side	74,9	76,3	82,0	84,5	86,5	88,2	81,4	84,7	92,7	dB(A)
		SPLa - Inlet Side	70,8	75,1	82,1	83,7	77,8	77,1	74,6	84,7	87,2	dB(A)

* The fan system effect is taken into account in the fan performance
 * The fan calculated for wet conditions
 * Sfp is calculated based on clean filter & dry coil conditions

ACCESSORIES (M5)

Lightening, Observation Glass	
-------------------------------	---

www.bskhavalandirma.com.tr Office Tel: +90 216 669 09 70 Factory Tel: +90 216 669 09 70
 info@bskhavalandirma.com.tr Office Fax: +90 216 669 09 72 Factory Fax: +90 216 669 09 72

